



**FLOW  
LEVEL  
PRESSURE  
ANALYTICAL  
TEMPERATURE  
INSTRUMENTATION  
PASTEURIZATION CONTROLS**

## Conductivity-based, solid state Modules and Probes for on/off liquid level switching and alarming

*Sanitary connections with one to four electrodes offers maximum flexibility*

*Stainless steel electrodes with optional Teflon® coating for optimum corrosion resistance and cleanability*

*Solid state plug-in modules with LED indicator provide compact, low cost switching or alarm contacts*

*Failsafe operation via direct or inverse mode switch action*

*Modules available in varying sensitivities for a wide range of fluid conductivities (800 to 450 K ohms/cm)*

*NEMA4X enclosure available for local mounting of modules*

The typical Anderson conductance probe-type liquid level system consists of two major components - the switching "module" and a sanitary probe with one or more electrodes.

The fixed-length electrodes are installed vertically with their lower ends positioned at the levels at which the switch is to be actuated. Electrodes are typically 1/4" type 316 stainless steel and may be optionally specified

with Teflon® coating for all but the exposed tip. Various probe fittings are available to match your existing process connection.

Switching modules are connected to the probes via a water-tight plug with integral cable. The module provides Form-C relay contacts for switching or alarming and is supplied with Single Pole/Double Throw (SPDT) contacts. Modules are designed for single level

or differential operation and are available in fixed or field adjustable sensitivity. A NEMA4X enclosure may be specified for mounting the switching module local to the probe.

Detailed specifications and ordering information can be found within this brochure or by visiting our website at [www.andinst.com](http://www.andinst.com).



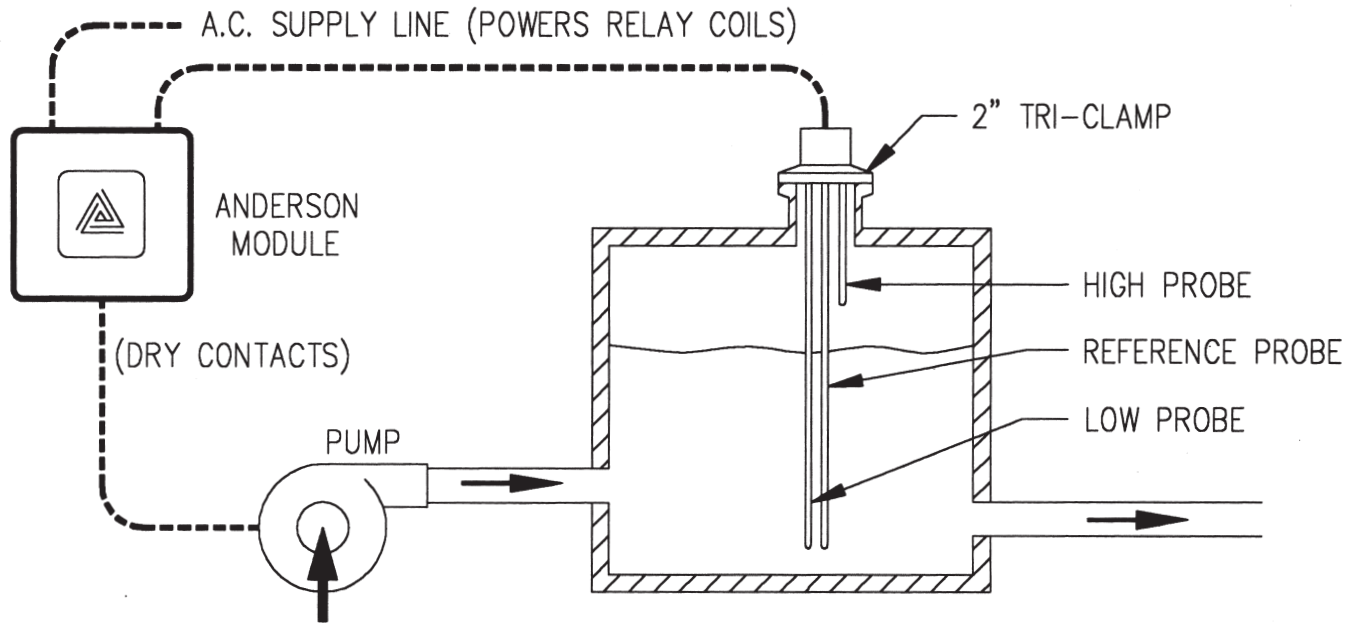

The drawing illustrates a typical control system installation handling a "pump-up" (inverse) operation. In this arrangement the pump starts when the liquid drops below the low probe and stops when the liquid touches the high probe for the purpose of replenishing liquid drawn from the vessel. The level varies but is maintained within the limits established by the tips of the probes. A "pump-down" (direct) application is opposite, with the pump starting at the high level and removing liquid from the tank until the low level probe is clear of liquid.

## TYPICAL FLUIDS: AVERAGE SENSITIVITY

<u>Liquid or Material</u>	<u>Sensitivity (Ohms/cm)</u>	<u>Liquid or Material</u>	<u>Sensitivity (Ohms/cm)</u>
Baby Foods	1K	Molasses	10K
Beer	2.2K	Mustard	1K
Bourbon	200K	Oil-Soluble	10K
Buttermilk	1K	Soap Foam	18K
Cake Batter	5K	Soups	1K
Catsup	2.2K	Starch Solutions	5K
Cream	1K	Sugar Solutions	90K
Cream (foam)	4.7K	Vinegar-Aqueous	2.2K
Coffee	2.2K	Water	
Corn Syrup	45K	Carbonated	3K
Corn-Cream Style	2.2K	Condensate	18K
Jams/Jellies	45K	Chlorinated	5K
Juices-Fruit/Vegetable	1K	Distilled	450K
Mayonnaise	5K	De-ionized	2.0M
Milk	1K	Hard/Natural	5K
		Wine	2.2K

Note: For low sensitivity liquids (milk, cream), when foam is normally present, use 800 ohm module sensitivity to ignore foam and 4.7K ohm sensitivity to sense foam.

## ON/ OFF SWITCHING MODULES

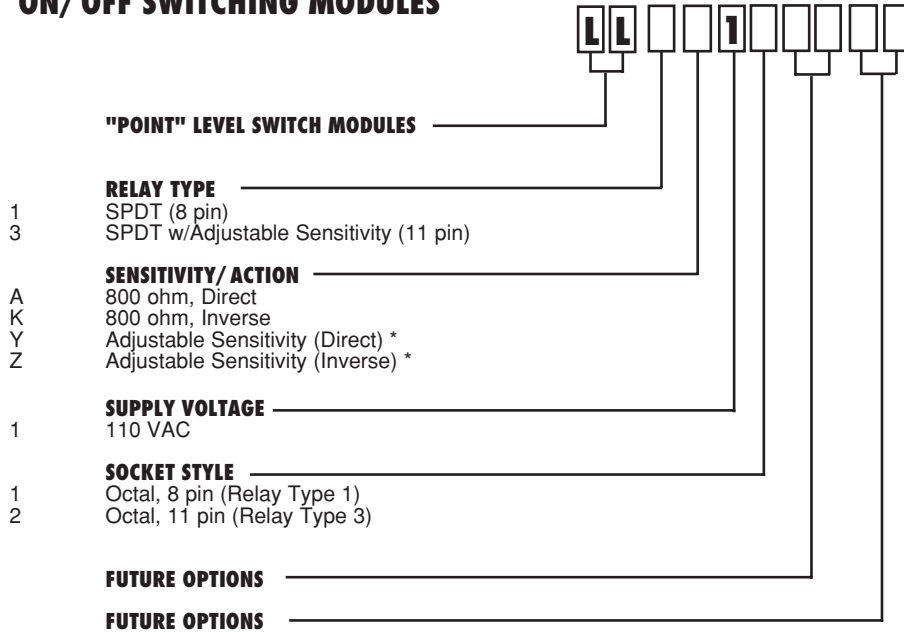

### Accessories:

NEMA4X Enclosure (includes mounting plate)	PN 73220-A1
Spring Clip for Module	PN 44930-A1
Adjustable Sensitivity Board (Socket Style 2 only) (One included with each type 3 relay)	PN 56014-R0070

**Note:** *Some multiple probe applications may require more than one Relay Module.  
Contact the Anderson Technical Service Department at 1-800-833-0081.*

**\* Unit supplied as 4.7K, adjustable sensitivity by customer supplied resistors, or  
p/n 56014-R0070, adjustable sensitivity board; (provides 5K to 700K ohms  
sensitivity adjustment) one included per module.**

## PROBE ASSEMBLIES

**BODY MATERIAL** \_\_\_\_\_  
 N Nylon  
 S Stainless Steel  
 (Available w/Teflon® coated probes only)

**FITTING** \_\_\_\_\_  
 A 2" Bevel Seat (Nylon Body Only)  
 B 2" Tri-Clamp®  
 C 1.5" TC (SS Body Only)

**TOTAL # OF ELECTRODES** \_\_\_\_\_  
 1 1  
 2 2  
 3 3  
 4 4

**ELECTRODE MATERIAL** \_\_\_\_\_  
 S Stainless Steel  
 T Teflon® Coated

**ELECTRODE LENGTHS \*** \_\_\_\_\_  
 00 None  
 06 6"  
 12 12"  
 18 18"  
 24 24"  
 30 30"  
 36 36"  
 42 42"  
 48 48"

Specify longest to shortest.  
 (Consult factory for longer lengths)

\* If a "reference" electrode is required, specify length to equal the longest "point" electrode.

## JACK/ CABLE ASSEMBLIES

**NUMBER OF ELECTRODES \*** \_\_\_\_\_  
 1 1  
 2 2  
 3 3  
 4 4

**CABLE LENGTH** \_\_\_\_\_  
 02 10'  
 04 20'

\* Note: Be sure to count total number, including reference electrode, if required.