

READ THIS FIRST

Installation and Startup Guide

Model HT Optical Transition Transmitter

Revision 3.1 Document 1118



Anderson Instrument Co., Inc.

156 Auriesville Rd. ~ Fultonville, NY 12072

Phone: 518-922-5315 ~ Fax: 518-922-8997

Reach us on the World Wide Web

www.andinst.com

This product carries a one (1) year warranty against manufacturers defects. A complete warranty statement is available by contacting Anderson, or in downloadable format from the World Wide Web.

PRODUCT DESCRIPTION

The Anderson HT Transmitter is an optical transition sensor that mounts directly to the process line, and provides real-time information about the process. The HT sends a beam of light into the product, and in turn, measures the amount of back scatter produced by solids suspended in the product. The resulting degree of light scatter is converted to a 4-20 mA signal output.

Using the above operating principals, the HT can accurately detect the point of transition from water to product. This is considered the primary application. In addition, depending on the degree of solids difference between the two materials, a product to product transition may also be detected.

OVERALL DIMENSIONS

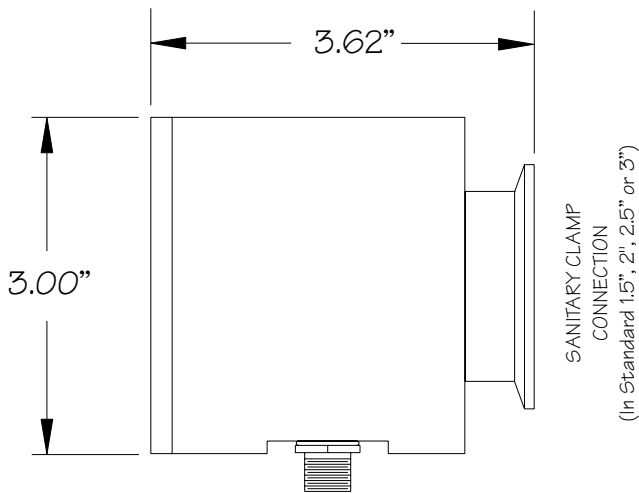

ORDER MATRIX



Fitting

- 004 1.5" Tri-Clamp
- 005 2" Tri-Clamp
- 006 2.5" Tri-Clamp
- 007 3" Tri-Clamp

Fixed Character

Cable Length

- 00 None
- 05 5m (16.4')
- 10 10m (32.8')
- 15 15m (49.2')
- 30 30m (98.4')

Factory cables supplied with molded "female" quick disconnect. (NEMA 1,2,3,4,6P,13 IEC IP68)

If using an alternate vendor, cables should mate to: Hirschmann: Part Number 932 878-100 ELST 512 PG9 (www.hirschmann-usa.com)

UNPACKING

Product Check:

Upon receipt, carefully inspect the product for damage to cables, connectors and sensor face. Damage claims should be made direct with carrier.

Factory Calibration

All units are supplied with a factory data sheet confirming the five (5) point calibration, along with mA output values.

Water = 4.00 mA To White Standard = 20.00 mA
(Four additional points provided on Cal Doc)

SPECIFICATIONS

Performance / Electrical

Accuracy: +/-0.2% of span at 4.00 mA (Water)
 Repeatability: +/-1.0% of span in any target fluid
 Response Time: 10 milliseconds
 Resolution: 0.10% of reading with typical calibration
 Process Temp Range: 32 to 190 deg F (continuous)
 Ambient Temp Range: 40 to 120 deg F
 Temperature Effect: 0.9% of span/10 deg F change (process and/or ambient) maximum
 Process Temperature Limits: Vacuum to 200 psig at rated temperature
 Output: 4-20 mA, 3 or 4 wire
 Power: 15-28 VDC, at 35 mA
 Connection: 5 pin, water-tight, with quick disconnect cabling

Mechanical

Housing Material: 316-series stainless steel
 Dimensions: 3.0" diameter x 3.6" length (approx.)
 Weight: 4lbs (approx.)
 Ratings: NEMA 4X (water-tight, corrosion proof)
 Authorized to carry 3-A symbol (Standard 46-03)
 Fitting: 316 series stainless steel finished to 32 R_a max.
 Optical Lens: Uncoated, optical sapphire (aluminum oxide) min. thickness = 2.3 mm
 Lens Seal: 60 durometer, FDA approved silicone rubber (meets ZZR-765-E, Class 2 A&B)

HT MOUNTING

- CAUTION -

Pay careful attention near the sapphire sensor face. Do not strike with hard or sharp object. Clean with soft cloth and mild soap solution.

Mount with connector downward in all installations

Piping Requirements

2" Minimum Depth

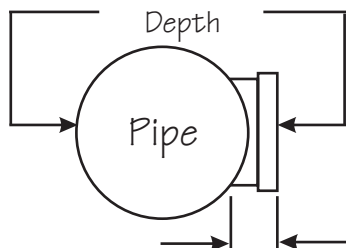

Make deadleg as small as possible

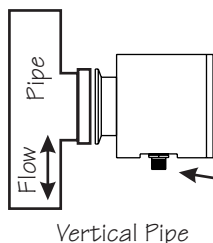

Vertical Pipe

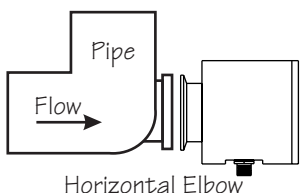

Horizontal Elbow

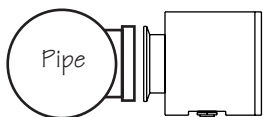

Horizontal Pipe

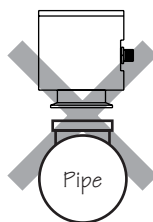

DO NOT mount HT on top or bottom of piping as resulting air space or sediment collection may cause erroneous readings

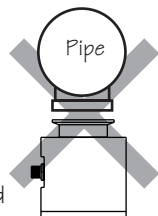

Standard Clamp and Gasket Required (Not supplied)

CABLE / SOCKET TERMINATIONS

Cable Terminations (If supplied)



- Brown Wire = -mA OUTPUT (- SUPPLY)
- White Wire = +mA OUTPUT
- Blue Wire = +15 to +28VDC SUPPLY (~35mA MAX)
- Black Wire = - SUPPLY
- Bare = SHIELD

Sensor Quick Disconnect Socket

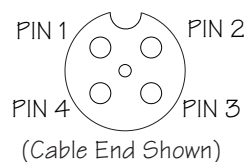

(Cable End Shown)

- PIN 1 = -mA OUTPUT (- SUPPLY)
- PIN 2 = +mA OUTPUT
- PIN 3 = +15 to +28VDC SUPPLY (~35mA MAX)
- PIN 4 = - SUPPLY

TYPICAL WIRING

3 Wire Connection

- White (pin 2) = + mA Output Signal
- Blue (pin 3) = + Power Supply (15 to 28 VDC)
- Black (pin 4) = - Power Supply (ground)

4 Wire Connection

- Brown (pin 1) = - mA Output Signal
- White (pin 2) = + mA Output Signal
- Blue (pin 3) = + Power Supply (15 to 28 VDC)
- Black (pin 4) = - Power Supply (ground)

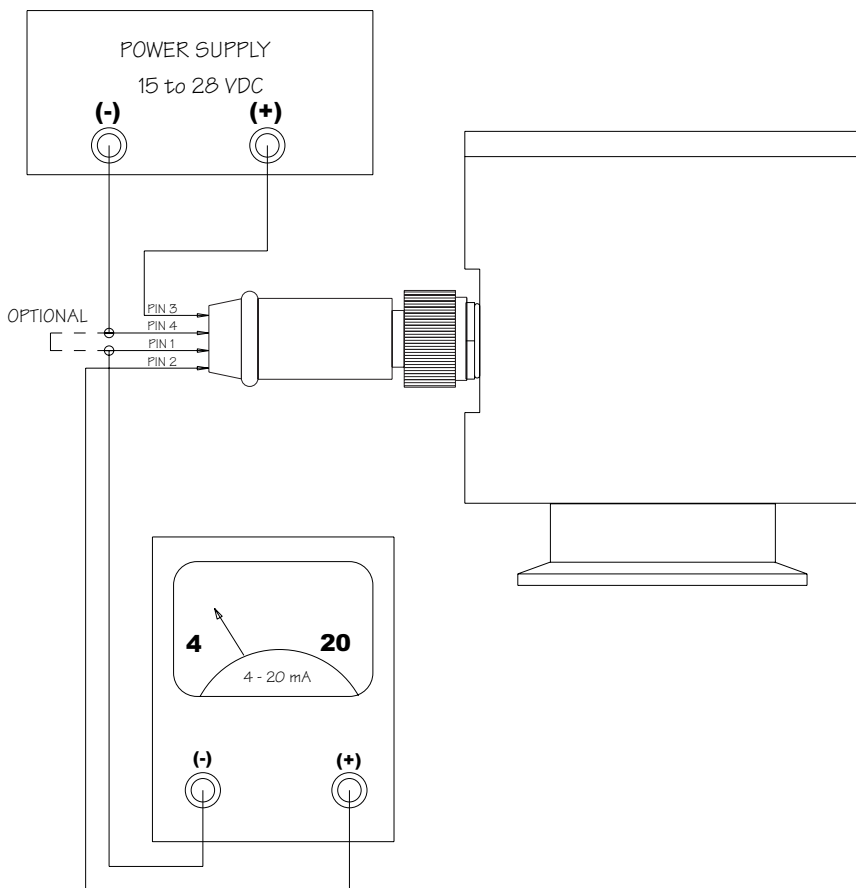

INTERNAL TERMINATIONS / ADJUSTMENTS

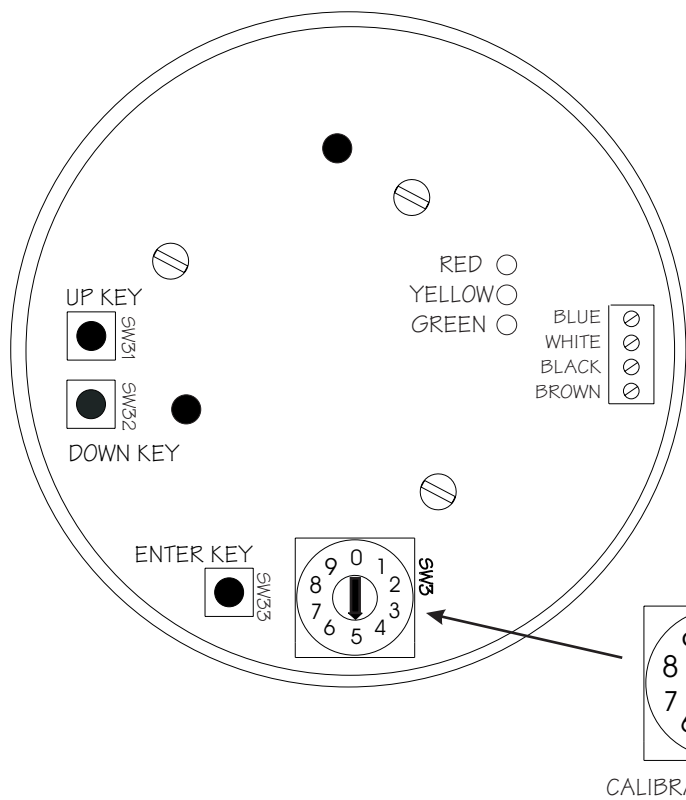

Power Supply Hookup
 BLACK = - POWER SUPPLY
 BLUE = + POWER SUPPLY

mA Output to Receiver
 WHITE = + mA
 BROWN = - mA (-SUPPLY)

BLUE = SOCKET PIN 3
 BLACK = SOCKET PIN 4
 BROWN = SOCKET PIN 1
 WHITE = SOCKET PIN 2

START-UP / COMMISSIONING PROCEDURE

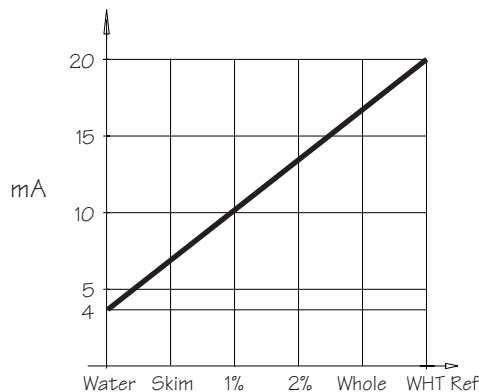

Utilizing Factory Calibration

As shown on the included Calibration Data Sheet, each unit is programmed to provide 4.00 mA in water, to 20.00 mA at Pure White Reference. In most cases, it is NOT necessary to modify this factory calibration. Utilizing the following procedure will allow development of a custom calibration table based on actual products present in the process.

1. First, obtain samples of all products that will be processed in this system. The most accurate results will be obtained if the product is at its normal processing temperature. You will need enough of each to fill a tee as shown.
2. Be sure the unit is properly wired to either the receiver, or to a multi-meter, so that you are able to view the corresponding signal output from the unit. When power has been supplied to the unit, The green LED on the electronics board will blink. Allow the transmitter to warm up for 15 minutes before proceeding.
3. Starting with the product containing the least amount of solids, fill the tee as shown.
4. Record the output for this product, then move to the next, ending with the product containing the greatest amount of solids. Please Note: When the sensor is operating within the current calibration range, the Green LED will blink alone. When over-range, the Green and Red LEDs will blink and when below range, the Green and Yellow LEDs will blink.
5. The resulting profile will correspond to the outputs from the unit at each of the various

Sensor should be wired to receiver, or to Multi-Meter as shown in "Typical Wiring Section"

Pour sample of product into "tee".
 Sensor must be horizontal to prevent air from causing erroneous readings.

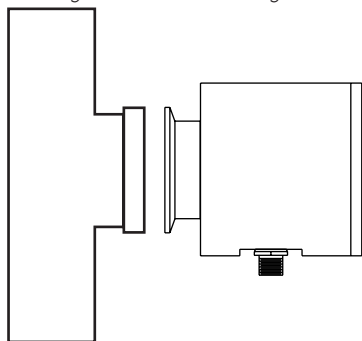

cap-off bottom end of "tee"

6 Month Calibration Check

It is recommended that the above procedure be performed on a 6 month basis in order to verify calibration of the HT sensor. Changes in product properties (solids content) are a common cause for discrepancy. If observed, follow the CALIBRATION section of this guide to re-set all product reference points

CALIBRATION

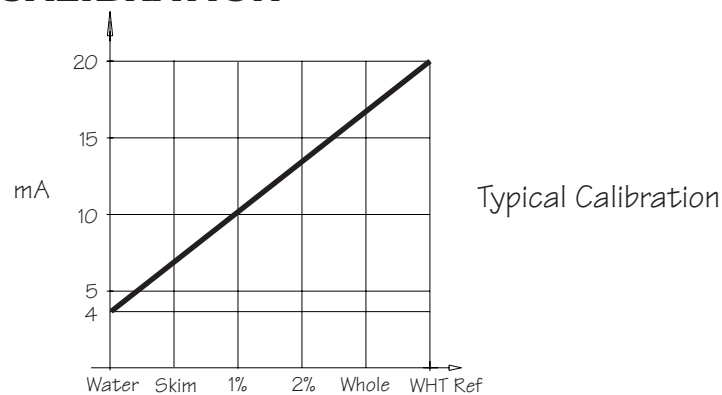

Typical Calibration

CAUTION

Starting the calibration sequence will erase ALL programmed points. DO NOT proceed unless samples are available for ALL products.

Field Re-Calibration

Utilizing the following procedure will allow development of a custom calibration table based on actual product samples. These samples may be milk based products similar to those used in the factory calibration, or consisting of another base.

1. First, obtain samples of all products that will be processed in this system. The most accurate results will be obtained if the product is at its normal processing temperature. You will need enough of each to fill a tee as shown.
2. Be sure the unit is properly wired to either the receiver, or to a multi-meter, so that you are able to view the corresponding signal output from the unit. When power has been supplied to the unit, The green LED on the electronics board will blink. Allow the transmitter to warm up for 15 minutes before proceeding.
3. Remove screw cap on sensor. Use caution so as not to damage rubber o-ring. Refer to the diagram shown in the "Internal Terminations / Adjustments" section of this manual to locate Calibration Switch.
4. As shown, fill the tee with clean water, or another fluid that you desire to be the 4.00 mA reference.
5. If the output is 4mA, there is no need to adjust. If you desire to change the zero point, turn the calibration switch to position "O", and press and hold the ENTER key until the yellow LED illuminates. Do not remove the sensor from the sample until the LED extinguishes. This will store the new value as 4mA
6. Remove the water, or optional base product, and fill the tee with the next highest solids content. So as not to introduce error in calibration, it is recommended that the tee be rinsed with water to clean any residue of the previous product from the face of the sensor.
7. Turn the CALIBRATION SWITCH to position 1. Press and hold the ENTER key until the yellow LED illuminates. Do not remove the sensor from the sample until the LED extinguishes. The sensor output will now be set to 20.00 mA (or the span setting).
8. Repeat step 7, incrementing the CALIBRATION SWITCH by one, until all points have been calibrated up to a maximum of 8. As points are added, each addition becomes the new 20.00 mA top end. Each previously entered point is linearly re-scaled.
9. In general, a five (5) point calibration is sufficient to provide proper output resolution. You may use calibration point 0 to 8. Point 9 is reserved for the Span Calibration, described below.
10. To obtain output values, the sensor should be placed again into each of the test liquids. With each product, record the resulting current output from the transmitter. The resulting profile will correspond to the outputs from the unit at each of the various products. These values can now be used as the reference for programming a receiver.

Sensor Offset & Span Calibration

The model HT sensor factory ships with a default value of 4.00mA output for the "base reference" position "O", and 20.00mA for span position "9". It is recommended that the unit be used in this configuration. The following procedure illustrates steps to either verify, or modify these values:

1. Remove the screw cap on sensor. Use caution so as not to damage rubber o-ring. Refer to the diagram shown in the "Internal Terminations / Adjustments" section of this manual to locate Calibration Switch.
2. Be sure the unit is properly wired to either the receiver, or to a multi-meter, so that you are able to view the corresponding signal output from the unit. When power has been supplied to the unit, The green LED on the electronics board will blink. Allow the transmitter to warm up for 15 minutes before proceeding.
3. Note the position of the Calibration Switch.
4. If you wish to change the "base reference" value place Calibration switch in Position "O" and simply press the UP or DOWN adjustment keys to obtain the desired output (4.00 mA). Quickly tap the key to make small adjustments. Press and hold the ENTER key until the yellow LED extinguishes to lock in the value.
5. If you wish to change the span value place Calibration switch in Position "9" and simply press the UP or DOWN adjustment keys to obtain the desired output (20.00 mA). Quickly tap the key to make small adjustments. Press and hold the ENTER key until the yellow LED extinguishes to lock in the value.
6. Return the Calibration Switch to its original position as noted in step 3. Replace cap.

Sensor should be wired to receiver, or to Multi-Meter as shown in "Typical Wiring Section"

Pour sample of product into "tee".

Sensor must be horizontal to prevent air from causing erroneous readings

